

Chemical Equations- Stoichiometry and Reaction Types

Translating words to symbols:

sodium reacts with sulfur to form sodium sulfide

Terminology

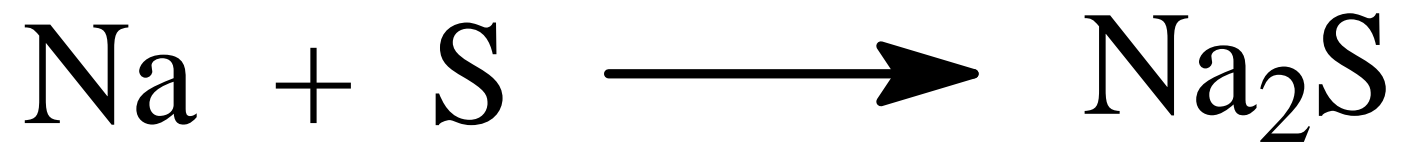

Diatomic Elements

Several elements exist in nature as molecules
with 2 atoms covalently bonded



Q1

magnesium reacts with oxygen to form ?????

Balancing Equations

After correctly writing symbols, place numbers in front of correctly written symbols to have the same number of atoms on both sides of the arrow

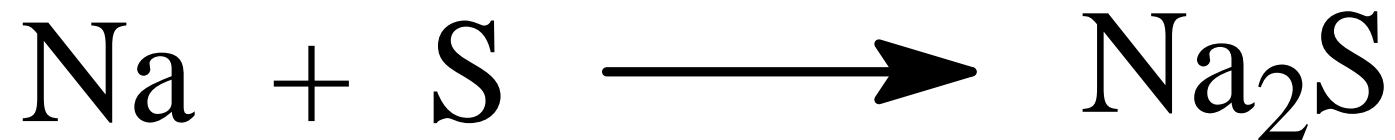

Q2

Balance the Q1 equation.

Meaning of a Balanced Equation

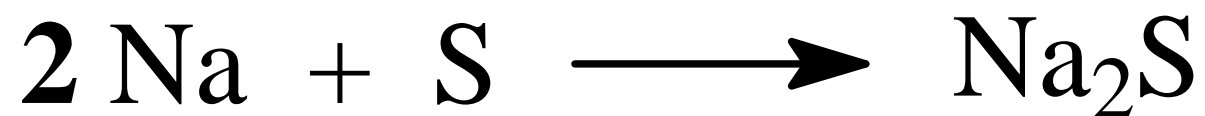

Identities Can Be Written

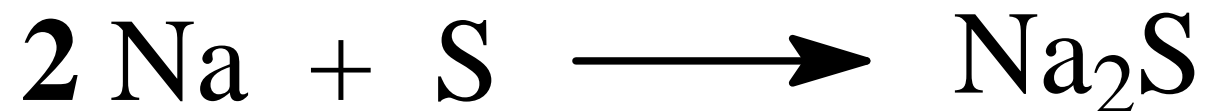

2 mols Na = 1 mol S

2 mols Na = 1 mol Na₂S

1 mol S = 1 mol Na₂S

Q3

Write all identities for the balanced reaction of magnesium and oxygen.

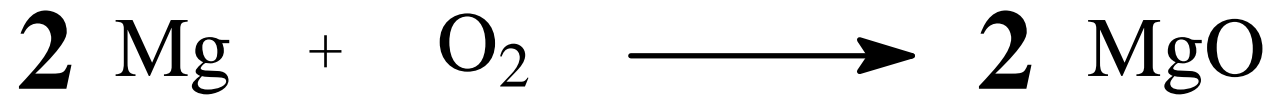

Q4

Complete, balance and write identities for:
aluminum reacts with chlorine

A Stoichiometry Problem

**For the reaction of sodium with sulfur,
how many grams of sodium are required
to react with 135g of sulfur?**

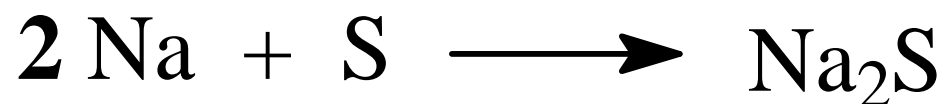

1. diagram the problem

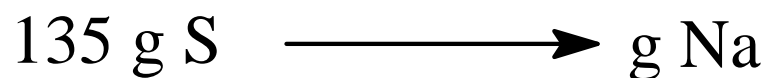

2. write the identity you need for this problem
based on the equation

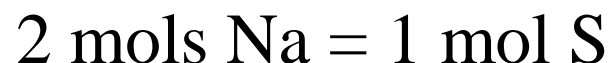

Continue

3. fit it into your diagram

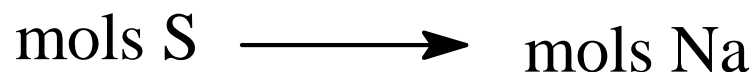

4. complete the diagram with identities still needed

5. Do the problem

$$135 \text{ g S} \left(\frac{1 \text{ mol S}}{32.07 \text{ g S}} \right) \left(\frac{2 \text{ mols Na}}{1 \text{ mol S}} \right) \left(\frac{22.99 \text{ g Na}}{1 \text{ mol Na}} \right) = 194 \text{ g Na}$$

Q5

How many grams of aluminum chloride can be made from 36.7 g chlorine,
according to

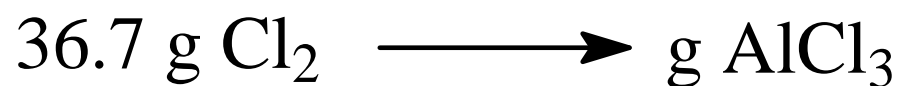
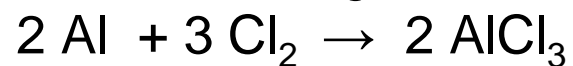

Combination Reaction

This is the reaction we've been working with so far

Combustion (oxidation, burning)

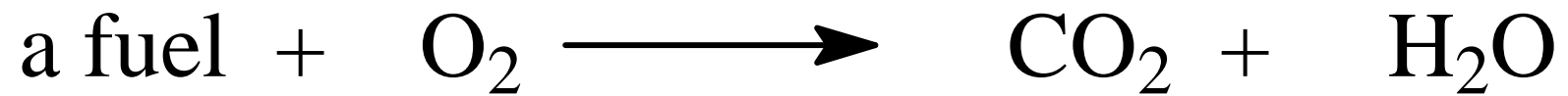

The Combustion of Propane

C_3H_8

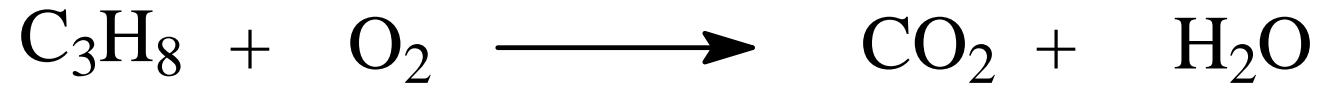

Q7&Q8

Write a balanced equation for the combustion of hexene, C_6H_{12}

Do the same for butane, C_4H_{10}

Q9

How many grams of CO₂ are produced when 385 g of propane are burned?

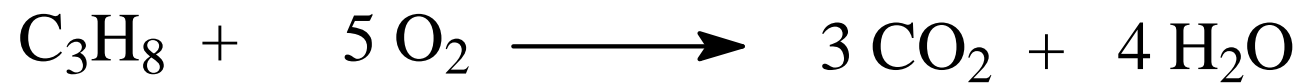

Subscripts used for states of matter

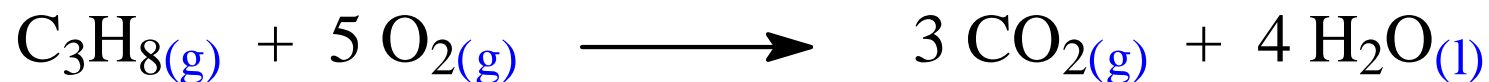

**You need only know what they mean
(you are not responsible for knowing all the states)**

Gas Stoichiometry

properties of gases

Macroscopic

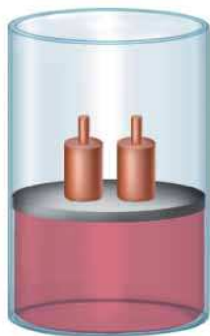

(a)

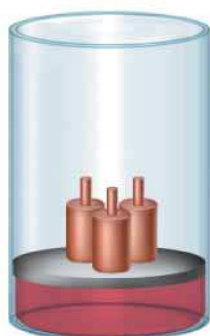

(b)



(c)

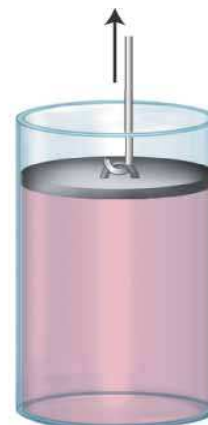

(d)

Particulate

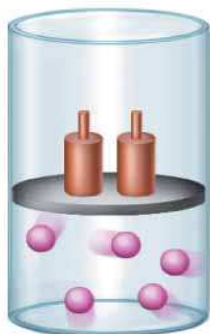

(a)

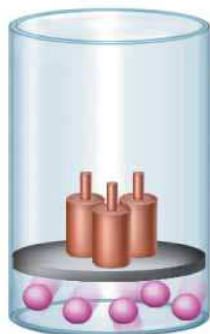

(b)

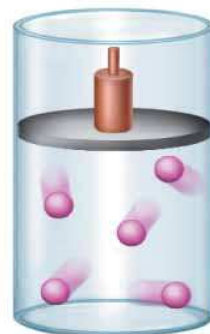

(c)



(d)

More

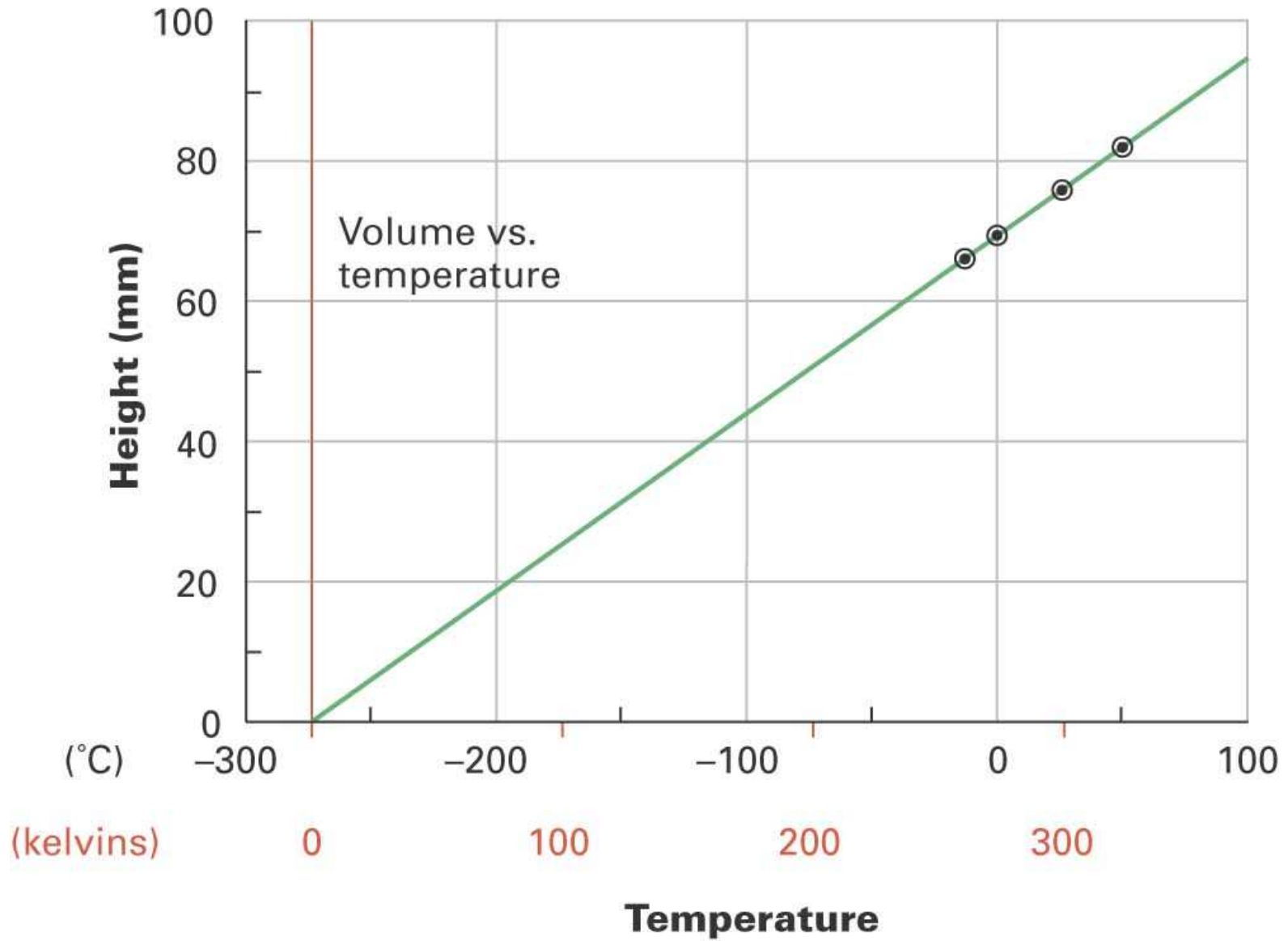

Finally

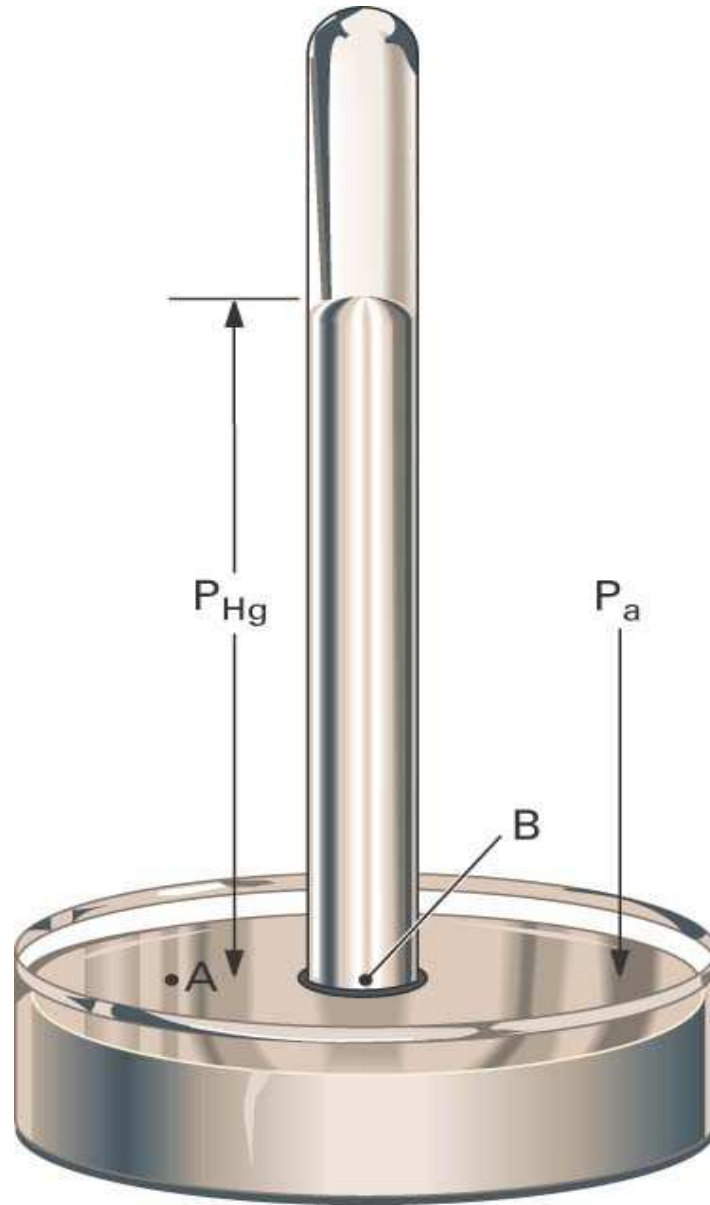

Molar Volume of a Gas

**At standard temperature and pressure (@STP)
1 mol of any (ideal) gas occupies 22.4 L of volume.**

A Problem

How many liters of CO₂ are produced at STP
by the combustion of 23.3 g of propane?

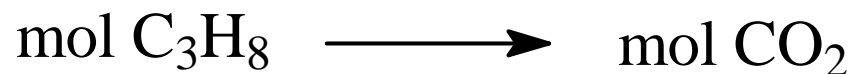
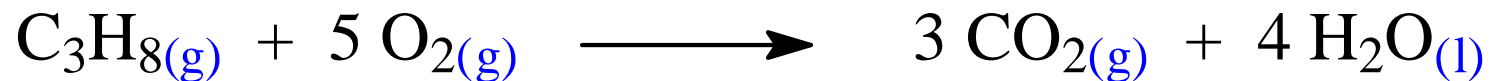

Q10

How many grams of hexene must be burned
to react with 17.5 L O₂ @STP?

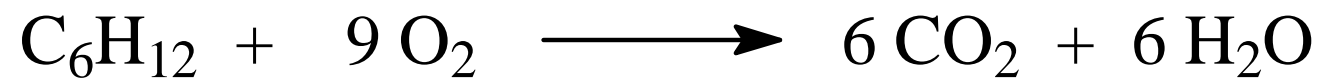

Double Displacement- the third reaction type

2 ionic compounds \longrightarrow **2 different ionic compounds**

potassium carbonate reacts with aluminum nitrate \longrightarrow ?

Q12

Complete and balance the following.

magnesium chloride + sodium sulfate

scandium chromate + calcium bromate

Single Displacement- the fourth reaction type

active metal + acid \longrightarrow ionic compound + hydrogen gas

magnesium + hydrochloric acid \longrightarrow ?

Q14

Complete and balance:

potassium + sulfuric acid →

aluminum + nitrous acid →

Also Single Displacement

an active metal + ionic compound \longrightarrow a less active metal + ionic compound₂

calcium + magnesium nitrate \longrightarrow calcium nitrate + magnesium

Q15

sodium + aluminum sulfate →

Neutralization (acid/base)- the fifth reaction type

acid + metal hydroxide (base) \longrightarrow ionic compound + water

nitric acid + barium hydroxide \longrightarrow barium nitrate + water

Q16

perchloric acid + magnesium hydroxide →

phosphoric acid + sodium hydroxide →

Decomposition- the sixth reaction type

A compound may be decomposed to:
other compounds
to the elements
to any combination of compounds and elements

potassium chlorate decomposes to potassium chloride and oxygen gas

water can be decomposed to the elements by an electrical current

Q17

Write both reactions and balance

potassium chlorate decomposes to potassium chloride and oxygen gas

water can be decomposed to the elements by an electrical current

.

Thermochemical Equations

During the process of a chemical reaction, energy is often given off (exothermic) or absorbed (endothermic)



identities can be written:

$$1 \text{ mol CH}_4 = -3245 \text{ kJ}$$

$$2 \text{ mol O}_2 = -3245 \text{ kJ}$$

$$1 \text{ mol CO}_2 = -3245 \text{ kJ}$$

$$2 \text{ mol H}_2\text{O} = -3245 \text{ kJ}$$

A Problem

How much energy is released when 85.0 g of H₂O are formed in the given reaction?



mol H₂O



Q18

How many grams of CO₂ must be formed to release 1230kJ according to:

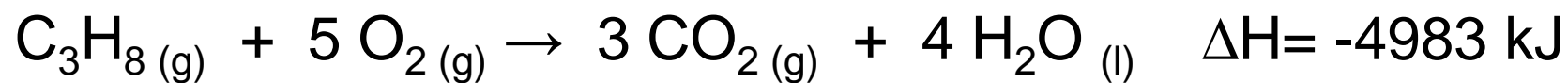

Another Look of Thermochemical Equations

Since energy is absorbed in endothermic reactions,
energy can be considered a reactant.

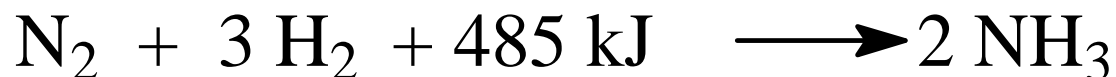

In exothermic reactions energy is produced,
therefore a product.

